



The B&B 5 leg giant jack is ideal for large diameter pipes (up to 36") and its V-head can be equipped with multiple options.

The 5 leg giant jack can be fitted with caster wheels, allowing pipe movement.

The 5 leg giant jack is characterized by its increased steel dimensions throughout, including 1 3/4" solid ACME rod, making it the toughest on the market.

Specifications

- Urethane over steel casters with solid hub increase safety and durability
- 5,000 lbs. capacity without wheels and casters
- 2,500 lbs. capacity with steel wheels and urethane casters
- Operating height with swivel casters: 32" - 44"
- Operating height with jack only: 24" - 36"
- Minimum - maximum pipe diameter 1" - 36"
- Solid 1 3/4" ACME-thread adjustment
- 1 1/2" wide steel / phenolic wheels to reduce instances of "pipe travel"
- Can be purchased as a complete kit as shown: jack, casters, and wheels
- Turning wheels available in steel, stainless steel, and phenolic
- Multiple add-ons available, including stainless steel sleeves for contamination free fit-up, recommended hold down chain device for transport, ball transfer attachments for variation of pipe movement and more

MAXIMUM HEIGHT: 44"

MINIMUM HEIGHT: 32"

PART NO: 3510
5 Leg Giant Jack as shown

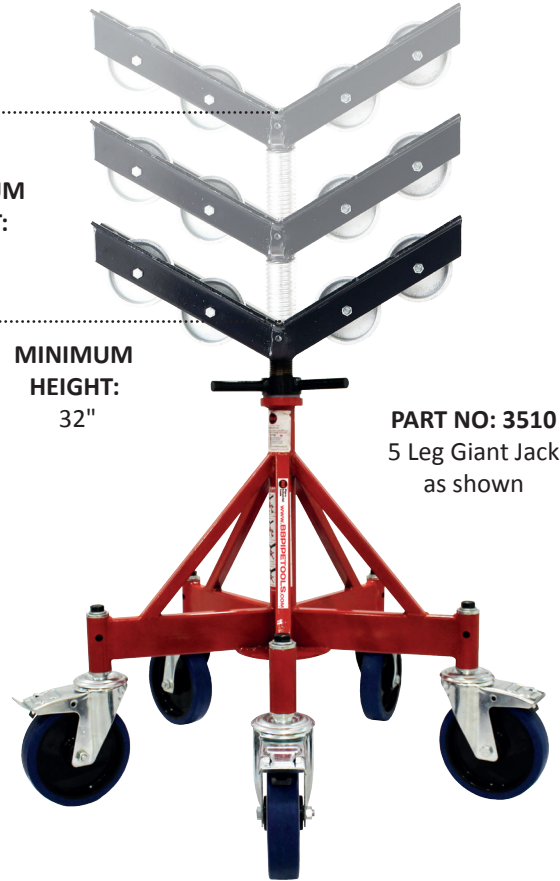

Transport pipes around the site or workshop with ease.



Shown with Part No: 3506 hold down chain device



Hold down chain device Part No: 3506 locks pipe to jack

PART NO: 3500
5 Leg Giant Jack as shown



HEIGHT: 36"- 25"
(no wheels, no casters)

5 LEG GIANT JACK HEAD OPTIONS

** Suitable for stainless steel*

PART NO: 3500

DESCRIPTION: 5 leg giant jack (base and V-head)



LOAD CAPACITY	WEIGHT	PIPE SIZE
5,500 lbs.	64.00 lbs.	2" to 36"

PART NO: 3510

DESCRIPTION: 5 leg giant jack kit ST (base, casters and steel wheels)



LOAD CAPACITY	WEIGHT	PIPE SIZE
2,500 lbs.	120 lbs.	2" to 36"

PART NO: 3502

DESCRIPTION: Steel wheel kit (4 wheels) - 1½" wide wheels



V-head not included

LOAD CAPACITY	WEIGHT
2,500 lbs.	12.30 lbs.

PART NO: * 3508

DESCRIPTION: Stainless steel wheel kit (4 wheels) - 1½" wide wheels



V-head not included

LOAD CAPACITY	WEIGHT
2,500 lbs.	12.30 lbs.

PART NO: * 3503

DESCRIPTION: Phenolic wheel kit (4 wheels) - 1½" wide wheels



V-head not included

LOAD CAPACITY	WEIGHT
1,000 lbs.	4.40 lbs.

PART NO: * 3509

DESCRIPTION: Ball transfer stainless steel (pair)



V-head not included

LOAD CAPACITY	WEIGHT
1,000 lbs.	6.60 lbs.

PART NO: * 3507

DESCRIPTION: Stainless steel sleeves (pair)



V-head not included

LOAD CAPACITY	WEIGHT
5,000 lbs.	2.20 lbs.

PART NO: 3506

DESCRIPTION: Hold down chain device



LOAD CAPACITY	WEIGHT
n/a	15.40 lbs.

PART NO: 3504

DESCRIPTION: Caster roller wheel kit for PN 3500 (5 casters)



LOAD CAPACITY	WEIGHT
2,500 lbs.	37.5 lbs.